

CRA-104-IBHH Steri-Guard[®]

Features:

- Prefabricated to field verified measurements
- Factory formed 3" radius wall returns and corners
- 12'-0" maximum length without butt-joints
- Corners factory formed to accommodate angles other than 90°
- Bracket standoff 3" standard (as shown)
1 1/2" and 2" standoffs are available

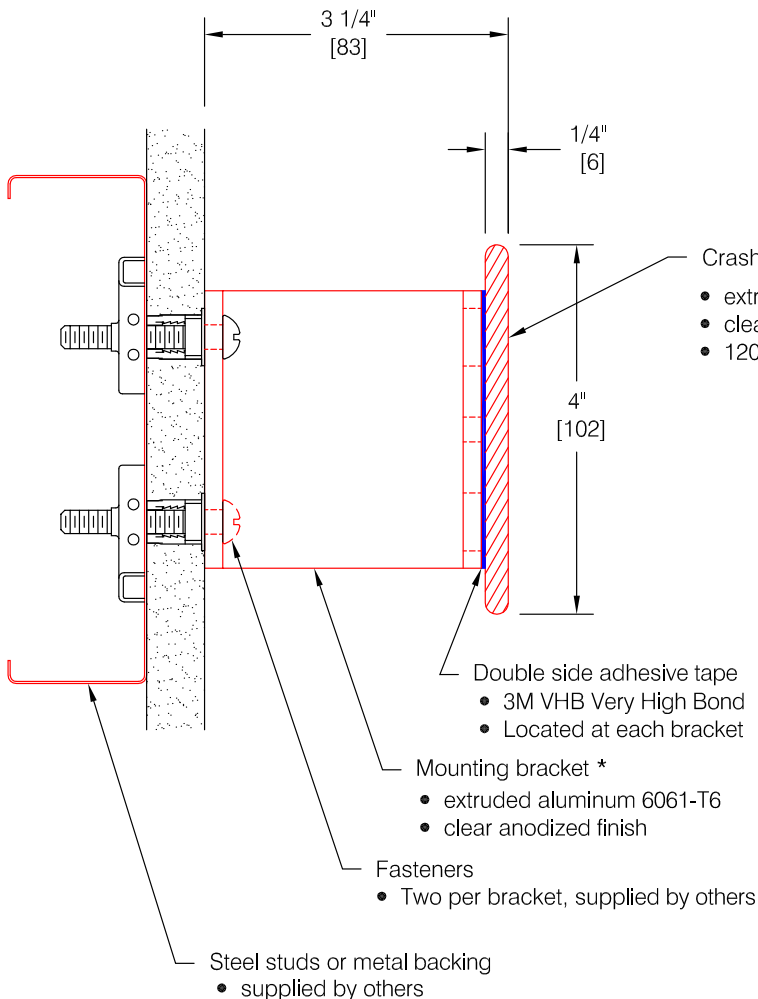

* Nominal bracket spacing 32" on center.
 Actual bracket spacing will vary according to jobsite conditions. Maximum spacing not to exceed 48" (1219).

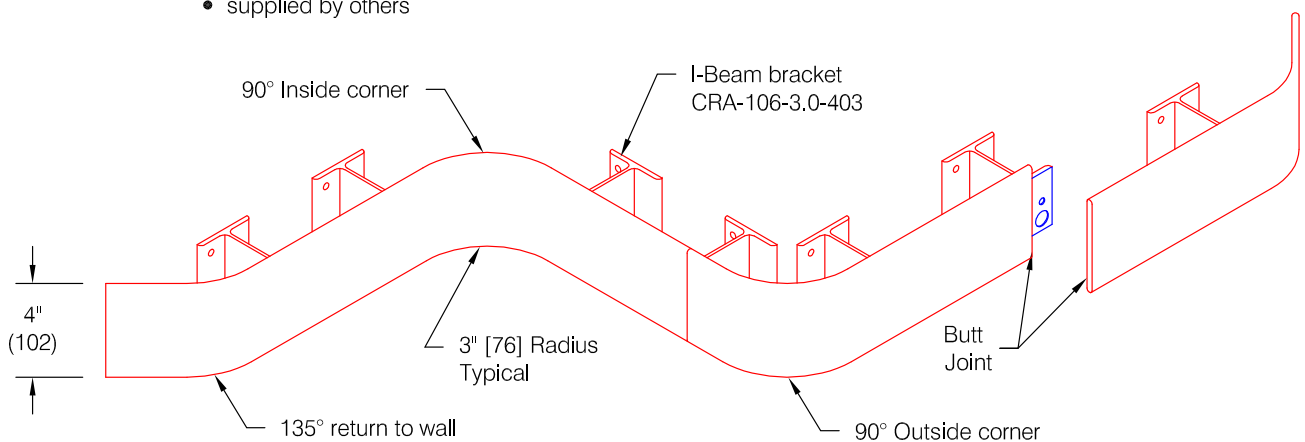
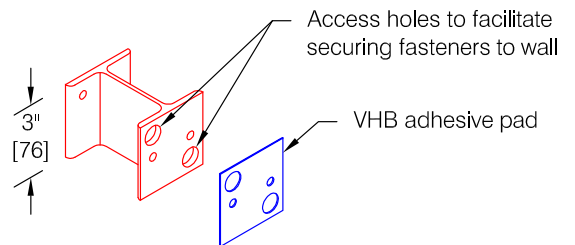

Pawling Corporation reserves the right to discontinue a design or modify an existing design without prior notice

Customer :	Project :	WD.201.3
Architect :	Sales Rep :	

CRA-104-IBSH Steri-Guard[®]

Features:

- Prefabricated to field verified measurements
- Factory formed 3" radius wall returns and corners
- 12'-0" maximum length without butt-joints
- Corners factory formed to accommodate angles other than 90°
- Bracket standoff 3" standard (as shown)
 1 1/2" and 2" standoffs are available

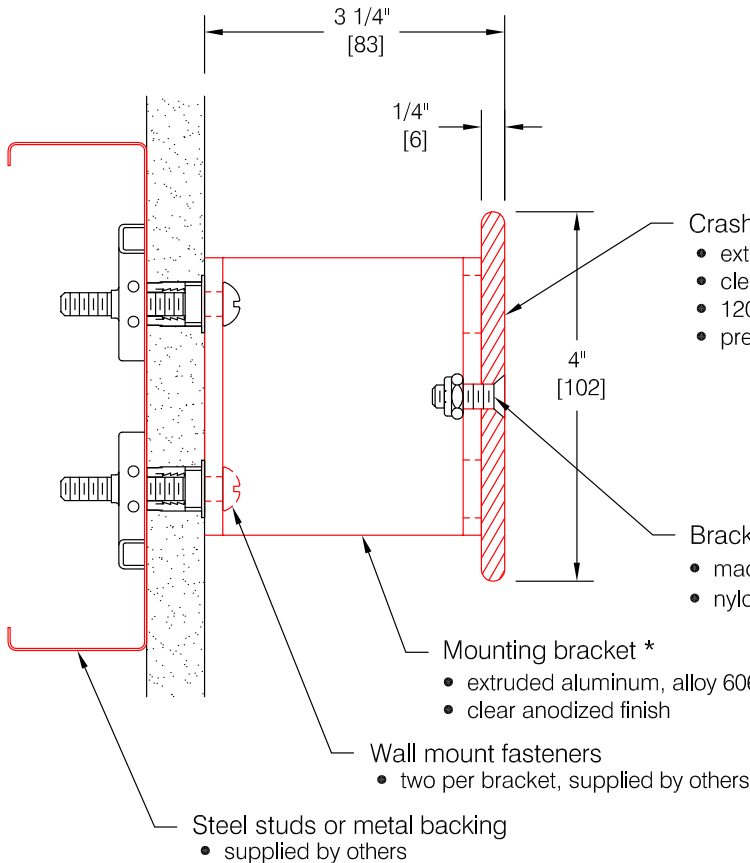

* Nominal bracket spacing 32" on center.
 Actual bracket spacing will vary according to
 jobsite conditions. Maximum spacing not to
 exceed 48" (1219).

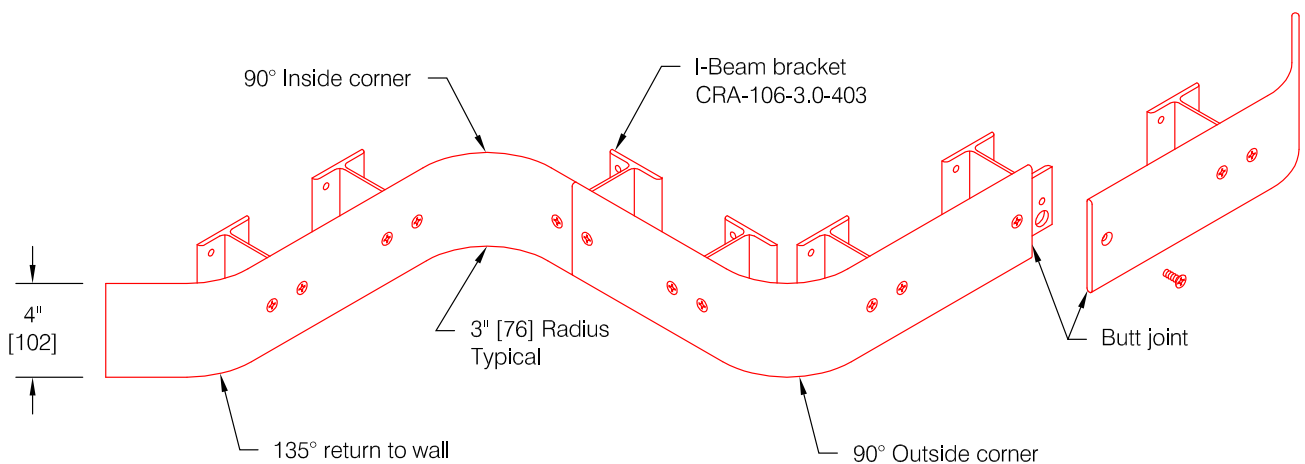
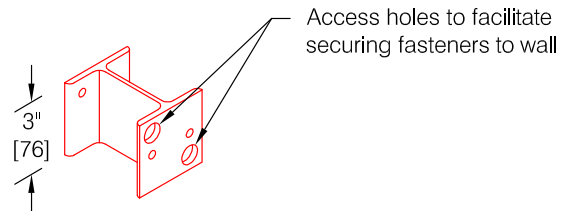

Pawling Corporation reserves the right to discontinue a design or modify an existing design without prior notice

Customer :	Project :	WD.201.0
Architect :	Sales Rep :	

CRA-104-TBSH Steri-Guard[®]

Features:

- Prefabricated to field verified measurements
- Factory formed 3" radius wall returns and corners
- 12'-0" maximum length without butt-joints
- Corners factory formed to accommodate angles other than 90°
- Bracket standoff 3" standard (as shown) custom standoffs are available

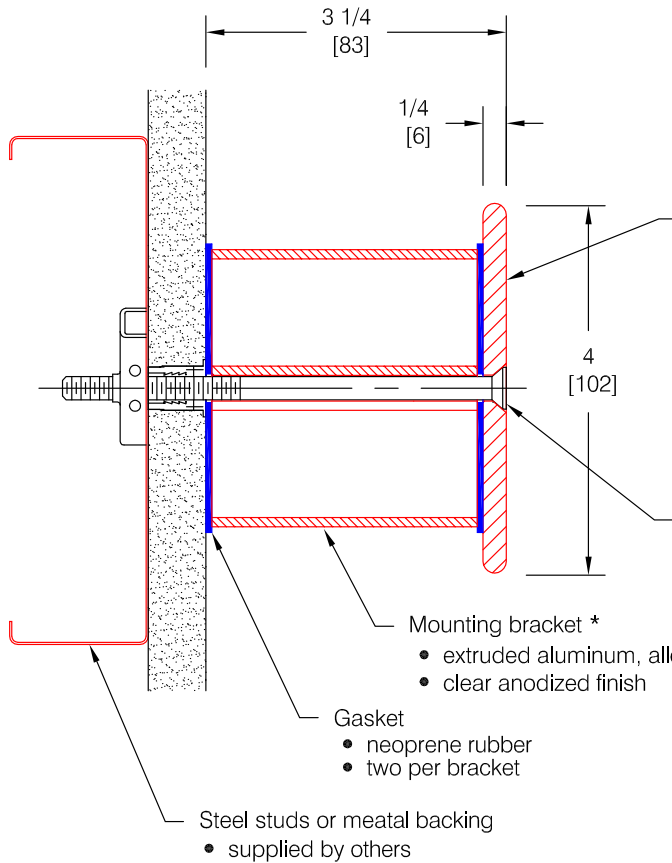

* Nominal bracket spacing 32" on center. Actual bracket spacing will vary according to jobsite conditions. Maximum spacing not to exceed 48" (1219).

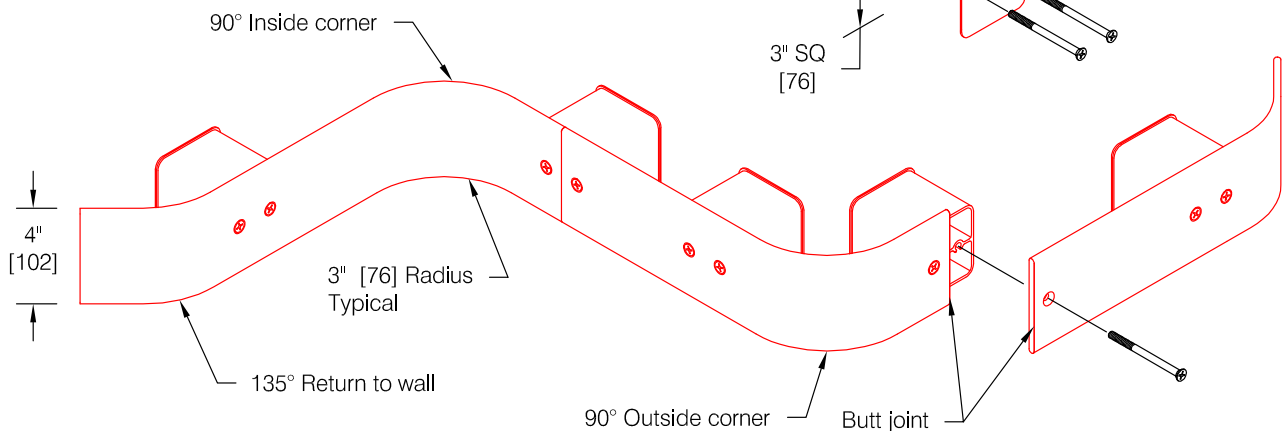
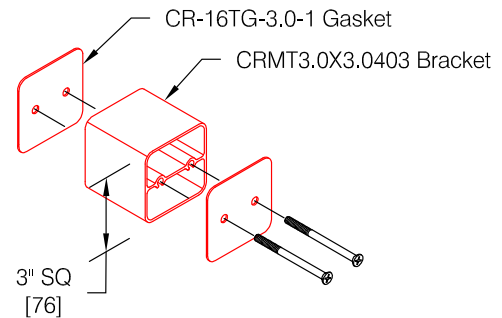

Pawling Corporation reserves the right to discontinue a design or modify an existing design without prior notice

Customer :
 Architect :

Project :
 Sales Rep :

WD.201.2a

CRA-104-ZBSH Steri-Guard[®]

Features:

- Prefabricated to field verified measurements
- Factory formed 3" radius wall returns and corners
- 12'-0" maximum length without butt-joints
- Corners factory formed to accommodate angles other than 90°
- Bracket standoff 3" standard (as shown) custom standoffs are available

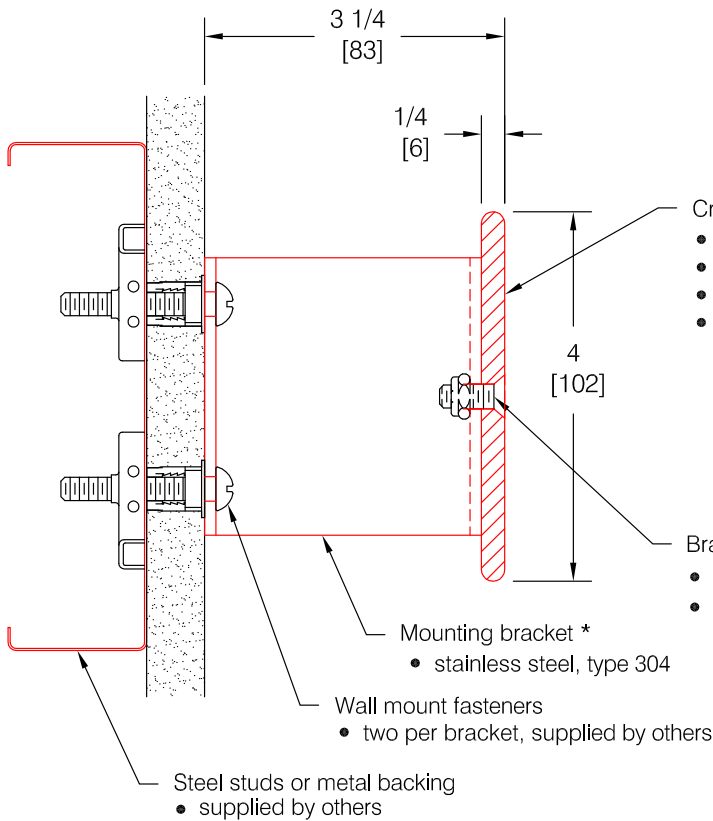

* Nominal bracket spacing 32" on center. Actual bracket spacing will vary according to jobsite conditions. Maximum spacing not to exceed 48" (1219).

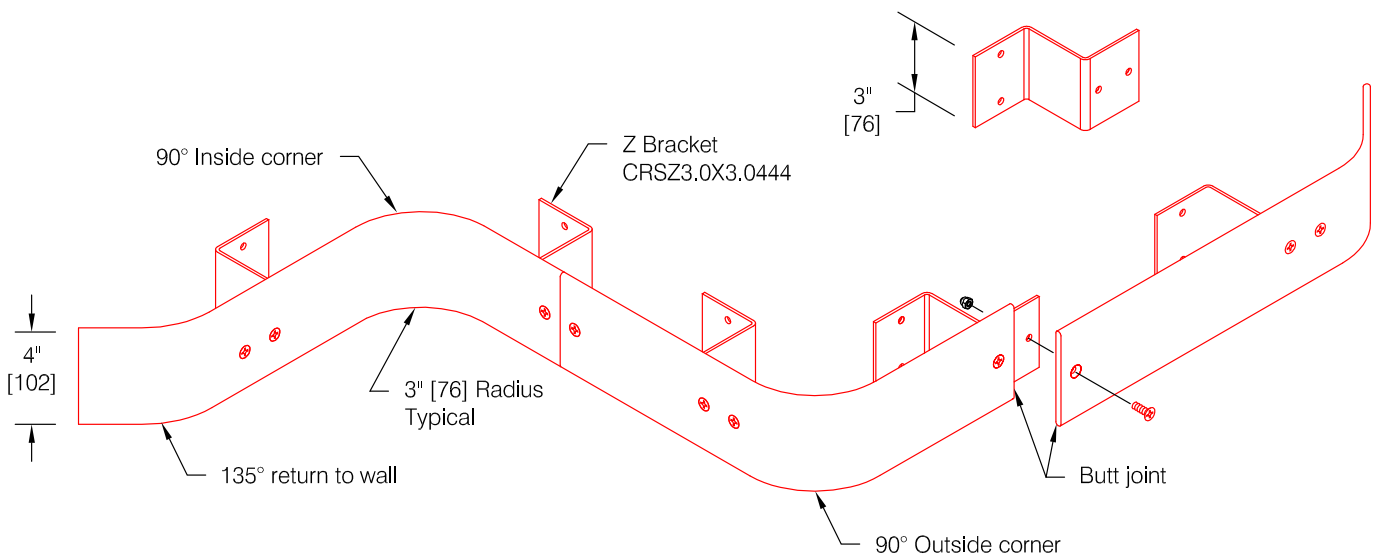

Pawling Corporation reserves the right to discontinue a design or modify an existing design without prior notice

Customer :

Project :

Architect :

Sales Rep :

WD.201.1a